



GENERAL COMMENTS

The majority of students made a good attempt at the 2012 Systems Engineering examination. Most questions were well answered. A number of students who were able to complete the more difficult calculations struggled with some basic considerations; in particular, some of them answered multiple-choice Question 4 incorrectly and did not mention any safety issues when responding to Question 20.

The exam produced a wide range of results and most students performed equally well on both the mechanical and electrical/electronic sections.

Students should be aware of the following information.

- Students need to be careful with handwriting and diagrams. If the assessor cannot decipher what is written or drawn, no marks can be given.
- Students should show their working. Credit can be given for working even if the final answer is incorrect.
- Attempting a question in a number of different ways will reduce the marks awarded unless all methods are correct.
- Students need to read questions carefully. Giving a correct statement that does not answer the question will be marked as incorrect.

SPECIFIC INFORMATION

Section A – Multiple-choice questions

The table below indicates the percentage of students who chose each option. The correct answer is indicated by shading.

Question	%A	%B	%C	%D	%No answer	Comments
1	9	6	77	7	0	
2	23	17	53	6	1	The thread pitch is the distance between each thread. Rotate a bolt 180° or half a turn and the bolt will stretch 0.5 mm.
3	0	1	0	99	0	
4	89	4	1	6	0	
5	19	25	12	44	0	The connecting link is further from the pivot than the rotating cam, so the force is less.
6	4	7	64	24	0	Point A is the effort; the load is the connecting link.
7	49	41	3	7	0	As the cam goes down, the connecting link goes up so creating a low pressure.
8	22	24	37	17	0	Use of the equation torque = force × distance was needed. ($f = \frac{t}{d} = \frac{100}{0.4} = 250$ N).
9	16	52	25	6	1	Gear ratio is number of teeth driven: number of teeth driver = 2:1 × 3:1 = 6:1
10	5	3	44	49	0	Anticlockwise and slower
11	4	51	29	15	0	This question caused some confusion. The question asked about the force applied to the shank of the bolt, not the nut. The purpose of a nut and bolt is to hold things together in tension.



Question	%A	%B	%C	%D	%No answer	Comments
12	18	12	45	25	0	If the diameter of the wire increases, the resistance decreases and so the voltage will drop. Therefore, option A was the correct response. The other options were incorrect because for <ul style="list-style-type: none"> option B, a decrease in the wire diameter will increase the resistance and hence the voltage option C, a resistor parallel to the load will decrease the resistance of the circuit and hence increase the voltage across the voltmeter option D, the phrase 'when the circuit is operating' discounts this as the answer. No matter where you put the capacitor in this DC circuit, it will create an open circuit and no current will flow.
13	9	4	3	84	0	
14	56	17	8	18	1	The energy output is greater than the energy input. The battery will go flat.
15	62	8	5	24	0	The circuit can be reduced to a 30 R and a 60 R in parallel. These will give 20 R.
16	40	27	14	18	0	This question dealt with a similar principle as Question 12. A voltmeter has a very high resistance and must be placed across a load. Position A is in series with the circuit. Position B is in parallel with the battery and the loads. Position C is in parallel with only one resistor (if it was across both resistors in the branch it would be correct). Position D is across a wire and should be zero.
17	7	12	78	2	0	The LED gives out light. It does not detect it.
18	78	5	11	5	0	
19	15	47	22	16	0	
20	7	34	7	52	0	Only the light-dependent resistor can act as a sensor. The other answers are all output devices.

Section B – Short-answer questions

This report provides sample answers or an indication of what the answers may have included. Unless otherwise stated, these are not intended to be exemplary or complete responses.

Question 1

Marks	0	1	2	Average
%	21	28	51	1.3

1a.

Either of:

- oscillating motion
- reciprocating motion.

1b.

Rotary motion

Question 2

Marks	0	1	2	Average
%	82	4	14	0.4

There were several ways of completing this question. Many students incorrectly used the formula $F = P \cdot A$

2012 Assessment Report



$$\begin{aligned}
 F_1 \cdot d_1 &= F_2 \cdot d_2 \\
 120 \times 20 &= 2400\text{J} \\
 &= 15 \times F_2 \\
 F_2 &= 2400 \div 15 \\
 &= 160 \text{ N}
 \end{aligned}$$

Question 3

Marks	0	1	Average
%	44	56	

Class 2

Question 4

Marks	0	1	2	3	4	5	Average
%	17	22	27	17	8	9	

4a.

Two pushes per second \times 60 seconds gives 120 rpm.

4b.

Many students did not realise the difference between diameter and circumference. The diameter must be multiplied by π , ($0.25 \times 3.14 = 0.785$), then multiplied by the frequency of two pushes per second to give 1.57 ms^{-1} . Going from rpm to frequency caught some students out.

4c.

The description of the test was well done, but many students did not state the expected measurements. If a distance of 10 m was given, then a time of 2.5 seconds should also have been stated. Or if a time of 10 seconds was given, the car should have travelled 40 m.

Question 5

Marks	0	1	Average
%	69	31	

As the length of the pedal decreases, the effort required increases.

2012 Assessment Report



Question 6

Marks	0	1	2	3	4	5	Average
%	32	7	15	11	12	24	2.4

6a.

A rack and pinion was the most common correct answer. Any design that could be seen to work properly gained full marks. Some students managed to make the vehicle go left when they turned right.

The following is an example of a possible answer.

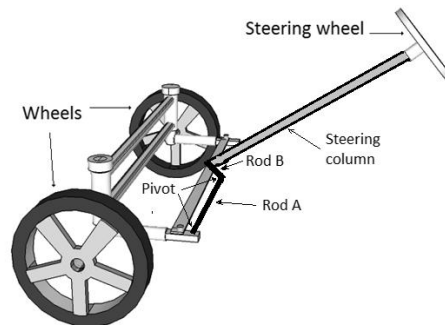

6b.

The description needed to correspond to the diagram. The description given often helps assessors to understand the student's design.

For the diagram above, the expected answer would be: As the steering wheel is turned to the right, rod B causes rod A to move left, hence the wheels turn right.

Question 7a.

Marks	0	1	2	Average
%	23	16	60	1.4

Some students gave components rather than processes. This highlights the need for students to read the questions carefully.

For example, processes could have been welding and using a hacksaw. Stating components such as rod A or the steering column gained no marks.

Question 7b.

Marks	0	1	2	Average
%	31	24	46	1.2

A safety precaution for welding is to use a welding helmet. A safety precaution for using a hacksaw is to hold the rod being cut in a vice.

Question 8

Marks	0	1	2	3	4	5	6	Average
%	10	11	12	15	18	20	13	3.4

8a.

The simplest solution was to realise that the ratio of the rpm was inversely related to the radius.

$$\frac{\text{rpm roller}}{\text{rpm disc}} = \frac{\text{radius disc}}{\text{radius roller}}$$

$$\frac{\text{rpm roller}}{1000} = \frac{.05}{0.1}$$

$$\text{rpm roller} = 500 \text{ rpm}$$

8b.

Either of:

- the rpm or the rubber roller will decrease

2012 Assessment Report



- if the roller moves too far to the right, it will make the rubber roller go in reverse.

8c.

Oil on the metal disc and rubber roller will cause a loss in friction. Friction is essential for the drive mechanism to work. The car will not move.

8d.

- Mechanical: The rubber roller needs to move further to the right. Some students who wrote this in part b. other rollers as their answer to this part.
- Electrical: A dpdt switch to reverse the current.

Question 9

Marks	0	1	2	3	4	Average
%	51	23	11	9	6	1.0

9a.

$$P = \frac{F}{A} \quad P = \frac{120}{\pi \times 0.02^2} = 381 \text{ kPa}$$

Students were required to give the units in their answers.

9b.

$$\begin{aligned} F &= P \times A \\ &= 381 \text{ kPa} \times \pi \times 0.03^2 \text{ m}^2 \\ &= 1080 \text{ N} \end{aligned}$$

$20 \times 3^2 \text{ N} = 1080 \text{ N}$ was another method.

Question 10

Marks	0	1	2	3	4	Average
%	20	19	17	21	24	2.1

10a.

Acceptable answers included any of:

- hydroelectricity
- wind power
- tidal power.

Answers needed to be a source of energy.

10b.

Using the source of energy to charge batteries was a common answer.

10c.

The answer needed to be relevant to the source of energy in **part b**. For example, for any of the three answers given in **part a.**, the environmental advantage is that no carbon dioxide or other waste product is produced in the production of electricity.

Question 11

Marks	0	1	2	Average
%	53	4	43	0.9

The unusual approach to efficiency caught many students out. Many tried to calculate 20% of 120 W.

$$\text{Efficiency} = \frac{\text{Energy out}}{\text{energy in}} \quad \frac{20}{100} = \frac{120}{\text{energy in}}$$

energy in = 600W

2012 Assessment Report



Question 12

Marks	0	1	Average
%	58	42	

$$0.9 \times 0.8 = 0.72 \text{ or } 72\%$$

The average of 90% and 80% (85%) was not accepted.

Question 13

Marks	0	1	2	Average
%	30	44	26	

Mechanical friction and electrical resistance were common correct answers.

Question 14

Marks	0	1	2	Average
%	50	6	43	

Each light is 12 V and 24 W.

$$I = \frac{P}{V} = \frac{24}{12} = 2A$$

Question 15

Marks	0	1	2	3	Average
%	30	30	26	14	

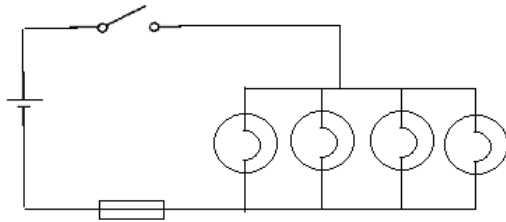

Question 16

Marks	0	1	Average
%	33	67	

There were many possible answers to this question. The most common were

- charge the battery in a well-ventilated area
- safety issues relating to wiring.

Question 17

Marks	0	1	2	3	4	Average
%	39	34	15	7	4	

17a.

Single Pole Double Throw



17b.

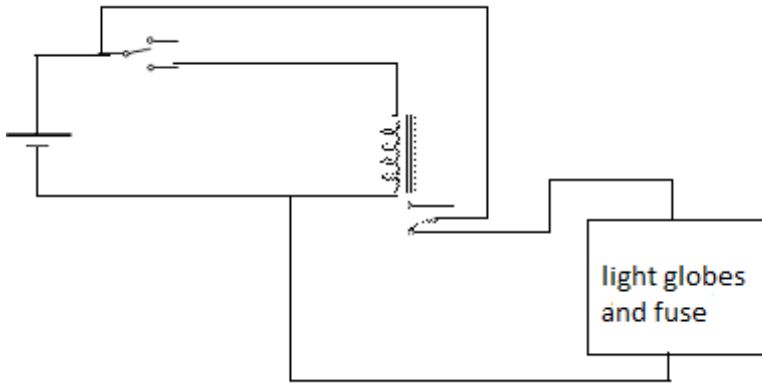

Question 18

Marks	0	1	2	3	4	Average
%	31	17	16	17	19	1.8

18a.

Red, violet, red, gold

18b.

Micro farad

18c.

- Name of component: transistor or NPN transistor
- Name of leg: base

Question 19

Marks	0	1	Average
%	85	15	0.2

Students found this question difficult. The concept being tested related to the capacitance increasing when the capacitors are in parallel. A second capacitor should be placed in parallel with C_3 . Even though the question stated that C_3 was not to be removed, some students still wanted to replace it.

Question 20

Marks	0	1	2	3	Average
%	21	11	29	40	1.9

This question was very well done; however, some students did not include any safety equipment; for example, safety glasses or a soldering-iron stand.

Question 21

Marks	0	1	2	Average
%	38	46	16	0.8

21a.

$$5 \times 2 = 10 \text{ volts}$$

21b.

The period is 150ms or 0.15 seconds. Therefore, $f = \frac{1}{p} = \frac{1}{0.15} = 6.67 \text{ Hz}$

2012 Assessment Report



Question 22

Marks	0	1	2	Average
%	37	45	18	0.8

Some students suggested pedals as an answer but they were not a part of the motorised vehicle. The question also asked for subsystems, not components. Appropriate mechanical subsystems were the steering system and the drive system. Appropriate electrical subsystems were the flashing-light subsystem and the electric motor.

Question 23

Marks	0	1	2	Average
%	42	12	46	1.1

Answers to this question varied, depending on the system chosen. The systems diagram needed to relate to the selected system. For example, if the drive system was selected, an input would be rotational energy from the motor and the output would be forward movement of the car (or rotation of the wheels).

Question 24

Marks	0	1	2	Average
%	60	11	29	0.7

24a.

For example, anti-lock braking system (ABS). If the brakes lock up, the electronics release the pressure on the brakes so that the wheels still rotate, giving the driver of the car more control. There is feedback from the sensors to adjust the pressure on the brake pads.

24b.

This style of question tends to challenge students. A closed-loop system requires a feedback line and often includes sensors of some sort. It is not a closed-loop system just because there is no human intervention. The interior light of a fridge turns on and off as if by a switch, but there is no human intervention to turn the light on. This does not make it a closed-loop system.